



application note

All you need to know about
SINAD and its measurement
using 2023 signal generators



The 2023A, 2023B and 2025 can be supplied with an optional SINAD measuring capability. This article explains what SINAD measurements are, when they are used and how the SINAD option on 2023A, 2023B and 2025 performs this important task.

What is SINAD?

SINAD is a parameter which provides a quantitative measurement of the quality of an audio signal from a communication device. For the purpose of this article the device is a radio receiver. The definition of SINAD is very simple - its the ratio of the total signal power level (wanted Signal + Noise + Distortion or SND) to unwanted signal power (Noise + Distortion or ND). It follows that the higher the figure the better the quality of the audio signal. The ratio is expressed as a logarithmic value (in dB) from the formulae $10\text{Log}(\text{SND}/\text{ND})$. Remember that this a power ratio, not a voltage ratio, so a factor of 10 in voltage is 20 dB.

For most applications SINAD is measured by setting up conditions so that the audio output contains a nominal 1 kHz tone. For a radio receiver this could be generated by applying an FM signal with a specified deviation at 1 kHz rate to the antenna. The audio output will have the 1 kHz tone present plus noise and distortion products.

To measure the SINAD ratio the audio output from the receiver is measured (wanted signal + noise + distortion) and then passed through a notch filter which removes the 1 kHz tone as shown in Figure 1. The resulting signal is measured (noise + distortion) and compared with the first measurement. The ratio is the SINAD value.

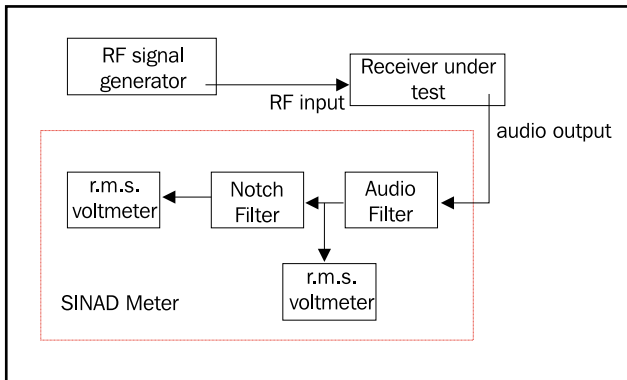

Figure 1.- SINAD measurement system

The measurement can be made either from an audio output or via an acoustic coupler from the loudspeaker.

For most radio systems the important SINAD numbers are usually between 12 dB and 20 dB (the threshold for reasonable intelligibility of voice) or the "ultimate" SINAD under ideal reception conditions, which is typically in excess of 40 dB.

The bandwidth of the audio signal is limited by a filter, which has the effect of limiting the amount of noise present and reflecting the ability of users to extract speech information from an audio signal. The audio filter restricts the bandwidth of the signal that is measured, concentrating the measurement on the important part of the voice around 1 kHz. For radio receivers the filters specified are usually based on those used in the fixed analogue telephony systems but, because of international differences in telephony systems two filters are commonly quoted.

C-MESSAGE filter used in North America

Psophometric filter specified in ITU-T Recommendation O.41, more commonly known from its original description as a CCITT filter (also often referred to as a P53 filter)

A third type of filter is also sometimes used which is unweighted (i.e. flat) over a broader bandwidth.

The telephony filter responses are tabulated in Figure 2. The differences in frequency response result in different SINAD values for the same signal. The C-MES signal uses a reference frequency of 1 kHz while the CCITT filter uses a reference of 800 Hz, which results in the filter having "gain" at 1 kHz. In performing the SINAD measurement however, the filters are effectively "normalized" to their 1 kHz value since the measurements are performed with a tone at this frequency and SINAD is inherently a ratiometric measurement.

Frequency (Hz)	Response (dB)	Tolerance (dB)	Frequency (Hz)	Response (dB)	Tolerance (dB)
60	-55.7	2	16.66	-85.0	
100	-42.5	2	50	-63.0	2
200	-25.1	2	100	-41.0	2
300	-16.3	2	200	-21.0	2
400	-11.2	1	300	-10.6	1
500	-7.7	1	400	-6.3	1
600	-5.0	1	500	-3.6	1
700	-2.8	1	600	-2.0	11
800	-1.3	1	700	-0.9	1
900	-0.3	1	800	0	0 (reference)
1000	0.0	0 (reference)	900	+0.6	1
1200	-0.4	1	1000	+1.0	1
1300	-0.7	1	1200	0.0	1
1500	-1.2	1	1400	-0.9	1
1800	-1.3	1	1600	-1.7	1
2000	-1.1	1	1800	-2.4	1
2500	-1.1	1	2000	-3.0	1
2800	-2.0	1	2500	-4.2	1
3000	-3.0	1	3000	-5.6	1
3300	-5.1	2	3500	-8.5	2
3500	-7.1	2	4000	-15.0	3
4000	-14.6	3	4500	-25.0	3
4500	-22.3	3	5000	-36.0	3
5000	-28.7	3	6000	-43.0	

Figure 2 - C-MES Response CCITT Response

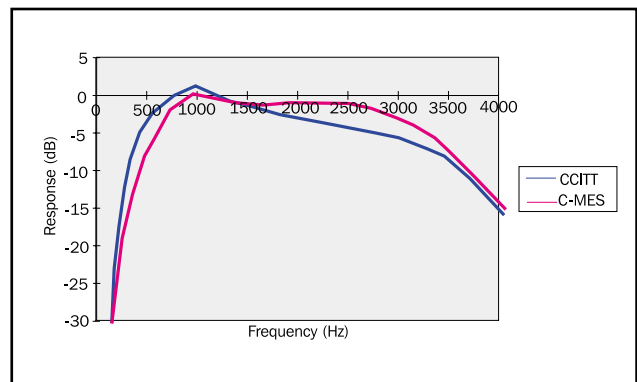

Figure 3 - Comparison of C-MES and CCITT Frequency Response

When used the filters clearly restrict the effects of harmonics on the SINAD measurement since only the second and third harmonics pass through the filters and contribute significantly to the measurement.

The ITU-T Recommendation O.41 specifies that the measurements in CCITT filters should be performed with an RMS (root mean square) detector (i.e. they are power measurements) and require that any alternative detectors used provide the same answer when measuring Gaussian noise signals, sine waves and any periodic signals having a peak to RMS ratio of less than 8 dB.

The notch filter used to remove the 1 kHz tone must be deep enough to ensure the tone is not passed onto the noise and distortion detector, but narrow enough to ensure that distortion and noise products are passed on.

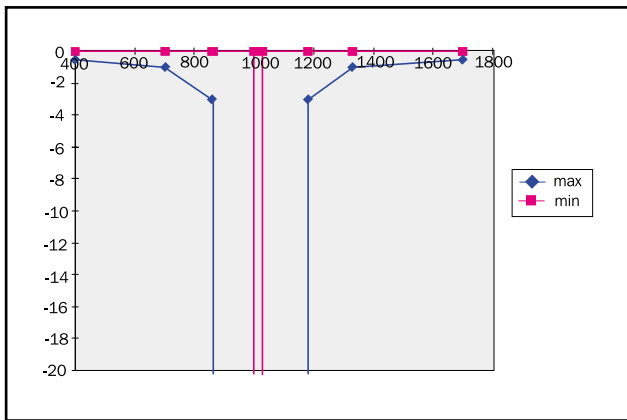

Figure 4 - Limits for Notch Filter ITU-T O.132

ITU-T Recommendation O.132 describes a filter used with 1.02 kHz tones for distortion measurements on telephone systems which requires the notch to be a minimum of 50 dB deep from 1 kHz to 1.025 kHz. For 1 kHz SINAD measurements the filter has to be adjusted for a 1 kHz centre frequency.

The European Telecommunications Standards Institute (ETSI) defines a notch filter in ETR O27 with the following characteristics for use in SINAD measurements:

2.2.3 Band-stop filter (for the SINAD meter)

The characteristics of the band-stop filter used in the audio distortion factor meter and SINAD meter shall be such that at the output the 1000 Hz tone will be attenuated by at least 40 dB and at 2000 Hz the attenuation will not exceed 0.6 dB. The filter characteristic shall be flat within 0.6 dB over the ranges 20 Hz to 500 Hz and 2000 Hz to 4000 Hz. In the absence of modulation the filter shall not cause more than 1 dB attenuation of the total noise power of the audio frequency output of the receiver under test.

The notch in ETR O27 is not as deep as that defined in the ITU Recommendation O.132. If the ultimate SINAD (i.e. under good conditions with a high input signal level) is to be measured a notch deeper than 40 dB is required.

WHEN ARE SINAD MEASUREMENTS USED?

Since SINAD measurements provide a quantitative measurement of audio quality from a receiver they can be used to assess the impact of different conditions on the radio performance. The principal measurements which require the use SINAD measurements are:

Reference sensitivity

The sensitivity of the radio to an RF input is measured to be

the RF signal level that is applied to its antenna input to obtain a specified value of SINAD. Values of SINAD are typically 12 dB or 20 dB and a 1 kHz modulating tone is used with a specified modulation depth (AM) or deviation (FM or F M). For FM analogue systems ETSI typically specifies the use of a deviation of 12.5% of the channel spacing.

Adjacent channel rejection

This parameter is an indication of the ability of the receiver to adequately demodulate the wanted signal when there is a strong interfering signal in the adjacent RF channel. In this measurement the reference sensitivity is typically measured, the RF level is then raised by 3dB and an interferer (a second source) is added in the adjacent channel which has a modulation tone at 400 Hz present. The interferer signal level is raised until the SINAD value is degraded to the original value obtained at the reference sensitivity. The ratio of the interfering level to the wanted signal is the adjacent channel rejection. The degradation in SINAD is typically caused by the 400 Hz tone becoming apparent in the audio signal which is passed by both the weighting filter and the notch filter.

Receiver intermodulation

This measures the ability of the receiver to reject two high level interference signals whose frequencies are chosen such that the third order intermodulation product falls at the receiver input frequency. Again it is found by finding the reference sensitivity, raising the wanted signal by 3 dB and then adding two more interfering signals of equal amplitude (one of which is typically modulated at 400 Hz rate) until the SINAD degrades to the original value. Intermodulation causes a co-channel interference to occur which again generates a 400 Hz interference tone. The receiver intermodulation is then the ratio of the interfering signal levels to the wanted signal level.

Receiver blocking

This is the ability of the receiver to reject a strong interfering signal far from the wanted frequency. It is measured again by finding the reference sensitivity, raising the signal level by 3 dB and then adding a CW interfering signal whose level is raised until the SINAD again degrades to the original value. An extensive search using different frequencies has to be performed to check for image and non linear behaviour in the receiver.

It can be seen that SINAD is used as a basic measurement technique for many of the important (and fundamental) receiver parameters. Its application is mainly relevant to analogue systems, but digital systems can also be measured in this way if the voice codec allows the generation of suitable test tones. The SINAD measurements are particularly useful for dual mode radios in North America supporting both digital systems and analogue AMPS systems.

Measuring SINAD with 2023 series Option 12

To simplify SINAD measurements the 2023A, 2023B and 2025 Signal Generators from IFR are offered with an optional built in SINAD meter. The RF output of the signal generator can

be used stimulate the receiver while the SINAD meter is used to measure the audio output.

The SINAD meter is implemented by an analogue to digital converter which converts the audio signal to a digital format and a digital signal processor (DSP) which compute the SINAD value. The DSP first filters the audio signal using a flat (unweighted) filter, a C-MES filter or a CCITT filter. The resulting RMS signal level (signal + noise + distortion) is computed as a reference value. The signal is then further filtered by the DSP to produce a notch filter which suppresses the 1 kHz tone. The RMS signal level of the resulting signal (noise + distortion) is then computed and compared with the first reading and the SINAD value computed and displayed on the LCD panel.

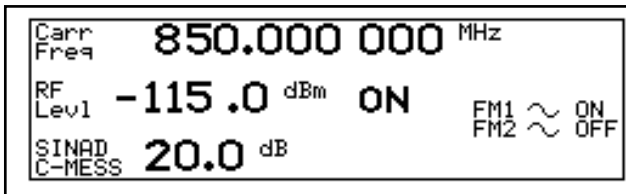

Figure 5 - SINAD display on 2023 series

The digital implementation ensures that the measurements are made quickly and very accurately. The C-MES and CCITT filters computed by the DSP are much more accurate than the traditional analogue filters, and since they are defined by a digital algorithm they are highly repeatable and stable with time and temperature.

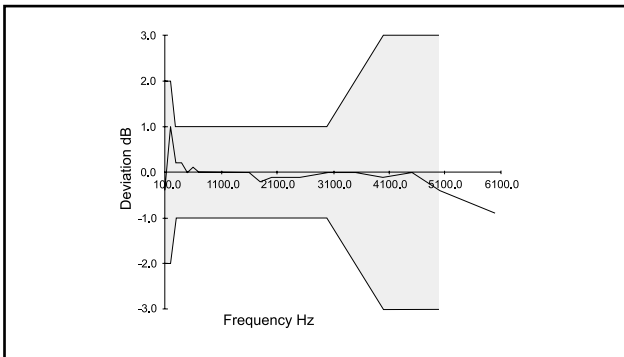

Figure 6 - Filter response compared to CCITT standard error band

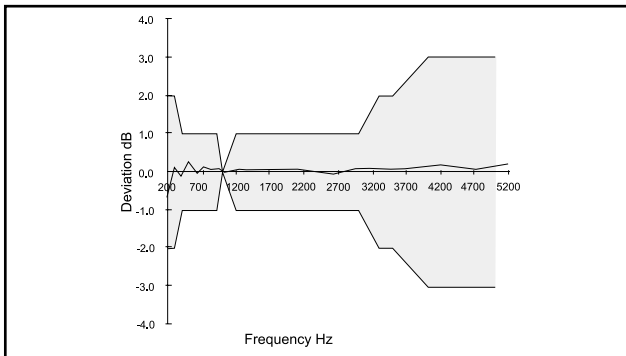

Figure 7 - Filter response compared to CMESSAGE standard error band

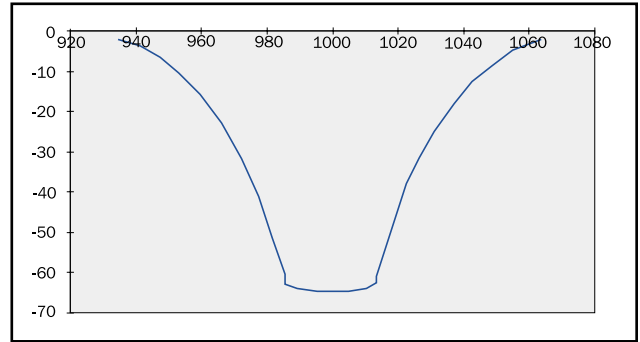

Figure 8 - Frequency response of the notch filter on 2023 series Option 12

The notch filter is also digitally implemented, allowing a notch to be generated which is deep, but has steep sides to maximize the amount of signal passed to the (noise + distortion) measurement stage while allowing some variation in the nominal 1 kHz tone frequency. The tolerance of the notch filter stop band to small frequency errors (approximately ± 25 Hz for -50 dB) is useful when dealing with signals generated from codecs where there is no guarantee that the input frequency is precisely the same as the output frequency. At frequency offsets of greater than 100 Hz the flat, low loss, filter response ensures that the measurement accuracy is excellent.

Since the signals being measured are noisy by nature there is some time variation in the value displayed. The use of digital techniques allows averaging to be performed simply over a number of measurement cycles. The signal generator defaults to an average over 5 readings but the user can set the averaging to between 1 (no averaging) and 127. Furthermore the use of digital techniques ensures that the measuring circuits are accurate true RMS responding with no errors introduced because of the detector techniques.

Use of automatic mode for SINAD measurements

When making measurements such as RF sensitivity, the user has to adjust the RF signal level until the required SINAD is obtained. The RF level set is then the required sensitivity. The 2023 series Option 12 SINAD Measurement has a unique automatic mode whereby the required SINAD is set (to, say, 20 dB) by the user and the signal generator then automatically lowers its RF output level from a preset value until the set SINAD is obtained. This can considerably simplify both manual testing and automatic testing.

To use the automatic mode the operator first sets the SINAD target and the initial RF level. An RF step size is set (using the increment facility) which is the amount by which the level is reduced for each step down in the algorithm. The user then starts the automatic mode and the generator automatically lowers its level until the required SINAD target is reached. For most applications a 1 dB step size is the most useful since a finer step size would require more averaging to be applied to overcome the unavoidable reading variance caused by the noise in the signal being measured. This in turn would increase the time taken by the algorithm to arrive at the required SINAD



target. Once the target SINAD has been reached the rotary control can be used to make finer adjustments to the level (if required) to get closer to the SINAD target.

GPIB measurement

Like all the other functions on the 2023 series, the SINAD option is fully supported over the GPIB. The GPIB control of the SINAD is simple to operate and has been designed to minimize the chances of an invalid response.

To find the current SINAD value a query is sent:

sinad: value?

The signal generator will return a single value in dB. The returned value is the average value over the number of measurements specified (also controllable over GPIB).

Compound queries such as:

sinad: value?; value?; value?

will return the appropriate number of measurement responses in one message, each measurement being from independent measurements. If three values are requested it increases the delay until the values are ready to sent. To reduce the controller waiting time the SRQ "mav" (message available) can be used to alert the controller when a measurement has been completed.

The weighting filters can also be selected over the GPIB. Whenever the weighting filter is changed it automatically restarts the measurement averaging to avoid erroneous results.

The system programmer needs to ensure that the timing of any system settling (including receiver AGC) does not disturb the SINAD measurement - if there is a danger of this happening two measurements can be requested and the first discarded.

SOURCES OF ERROR IN SINAD MEASUREMENTS

ETSI maintain a useful document, ETR 028, which describes methods of estimating measurement uncertainty on various parameters, including SINAD. Copies can be obtained through the ETSI documentation service, national standards organizations or from the ETSI CD ROM based document subscription service.

In principle SINAD measurements appear to be straightforward, but there are considerable opportunities for apparent differences in readings between different manufacturers' implementations, including the SINAD voltmeters, weighting filters and notch filters. The principle sources of errors are identified below:

RF Level errors

Uncertainty in the RF level applied to the receiver will result in errors either in the derived measurement (e.g. RF sensitivity) or the SINAD value. As the RF level is decreased the receiver noise in the audio output increases and the SINAD ratio reduces. For FM receivers this error can be compounded by the "capture effect" observed on receivers where a change in 1 dB of RF level causes a greater change in the SINAD value. RF level errors can be caused by a variety of effects including:

intrinsic RF level accuracy of the signal generator at low levels. This should include both response and attenuator errors (if separately quoted) and any environmental effects (temperature)

Example: At 1 GHz the RF level accuracy of 2023 series is ± 0.8 dB and has an environmental impact of ± 0.02 dB/°C outside the temperature range of 17° C to 27° C . For normal factory or laboratory use the environmental factors do not add to the uncertainty. The uncertainty is directly reflected onto the uncertainty of the RF sensitivity.

If the impact of RF level uncertainty is needed to be known (i.e. what is the SINAD at a specific RF level) then according to ETSI ETR 028 Section 5.3.2 an empirical relationship between SINAD and RF level in a receiver operating below the knee point (i.e. when the receiver is subject to the FM capture effect) is: $0.375 \text{ dB (RF Input Level)} = 1 \text{ dB (SINAD)}$. Applying to the above example this results in a SINAD uncertainty of $(0.8/0.375)$ or ± 2.13 dB.

Typically the uncertainty is much lower than this for 2023 series. VSWR effects. This is a particularly relevant factor because often the input impedance to a receiver is not well defined (and often not even intended to be 50 W) and a standing wave is generated between the signal generator and the receiver causing level errors in addition to those specified in the data sheet.

Example: At 1 GHz 2023 series VSWR is specified as 1.3 (max). If the generator is used to test a radio with an input VSWR of 1.5 the resulting standing wave causes an uncertainty in the delivered RF power according to the following formula:

$$\text{Power uncertainty} = 10 \log(1/(1 \pm \Gamma_s \Gamma_l)^2)$$

where Γ_s and Γ_l are the modulus of the reflection coefficients of the source and load respectively and are related to the VSWR by the formula:

$$\Gamma = (r-1)/(r+1)$$

Putting the example into the above formula $\Gamma_s=0.13$ and $\Gamma_l=0.2$

And inserting into the power formula the level uncertainty is approximately 0.22 dB.

The accuracy can be improved by masking the radio input VSWR using an attenuator pad on its input.

cable losses between the signal generator and the receiver input

Example: calculate as above for absolute level errors

All IFR signal generators feature good RF level accuracy and low output VSWR to minimise RF level errors.



RF leakage

From the signal generator. If the signal generator leaks RF signals they can add (or subtract) with the directly applied signals and cause RF level errors. This can be minimized by ensuring that the signal generator does not leak RF signals at its carrier frequency. All IFR signal generators feature low RF signal leakage to minimise this type of error.

To check for RF leakage effects add a high value 20 dB pad between the signal generator and the radio while it is operating at a level similar to the RF sensitivity. The SINAD ratio should worsen considerably (to less than 3 dB). Do not test using the level control or the carrier on off function since it changes the internal settings of the signal generator.

Modulation errors

If the modulation on the carrier is not accurate it will affect the audio level in the receiver and therefore affect the SINAD ratio. The excellent modulation accuracy of 2023 series ensures low modulation errors are introduced.

Example: On 2023 the FM modulation accuracy is $\pm 4\%$. To a first approximation this will have a similar effect on the SINAD

SINAD detector errors

The use of a detector with other than a true RMS responding characteristic will introduce an additional error which is hard to quantify since the mixture of signals which constitute the (noise + distortion) signal is a complex signal which varies between test situations and radio types. The SINAD option on 2023 series uses true RMS detectors which introduce negligible error.

Example for 2023: Negligible

Weighting filter errors

Errors in the frequency response of the weighting filter (C-MES or CCITT) will cause measurement errors which are dependent on the spectral content of the audio signal. The 2023 series SINAD option minimizes these errors by using a digital weighting filter which gives a very close and repeatable response compared with the theoretical filter.

Example for 2023: Less than 0.1 dB

Notch filter errors

The wider the bandwidth of the notch filter used to remove the 1 kHz tone the more noise and spurious signals it fails to pass on to the (noise + distortion) meter and "improves" the observed SINAD. In contrast if the notch is not deep enough it will pass on additional 1 kHz tones to the (noise + distortion) meter and make the observed SINAD appear worse than it is. The use of a digital filter on 2023 series SINAD option ensures a deep but steep sided notch filter which minimizes measurement error. The digital filter is able to produce a deep filter with a well defined narrow bandwidth and flat pass band

characteristics that minimizes errors in the SINAD measurement. The notch filter is sufficiently wide to allow some frequency errors in the 1 kHz tone without affecting the SINAD measurement.

Example. The ideal response is a very narrow filter at 1 kHz with virtually no bandwidth and a flat response outside this region. ETSI ETR 027 expects SINAD notches to have less than 1 dB impact on the noise + distortion measurement. The filter on 2023 has a noise bandwidth of approximately 150 Hz. Assuming the measurement bandwidth is around 3 kHz and the noise is reasonably "white" the filter removes around 5% of the signal or 0.21 dB. Compared to meters only just meeting the ETSI objective the 2023 will read 0.79 dB higher.

The above examples all give worse case analyses for the errors involved. In practice some of the errors may be lower in real systems. In particular the RF output level accuracy and VSWR of signal generators sometimes has the potential for "double counting" errors since the VSWR issues have to be taken into account since the manufacturers of the signal generator have to include an allowance for VSWR in their error budgets. For those with the ambition to do a more rigorous analysis ETSI ETR 028 provides a statistical approach to error analysis

The nature of some the errors in SINAD measurements makes it difficult to assign a definitive statement of the accuracy. However the excellent RF accuracy and VSWR of the 2023 series signal generators and the precise digital implementation of the SINAD meter facilities on Option 12 provide the users with simple and fast measurement results which have an accuracy much better than competitive solutions based on more traditional analogue technologies.

